

Intersections

Factory fabricated mitered corners and intersections are available. Intersections are available in standard styles, which are shown on this page. Custom shapes and designs are also available. The intersections are heli-arc welded. Six inch legs are standard. Longer legs—up to two feet in length—are available. Different size reveal widths and shapes can be intersected. Moldings can be miter cut and/or notched to meet special field conditions. Consult your Stockton sales representative for details.

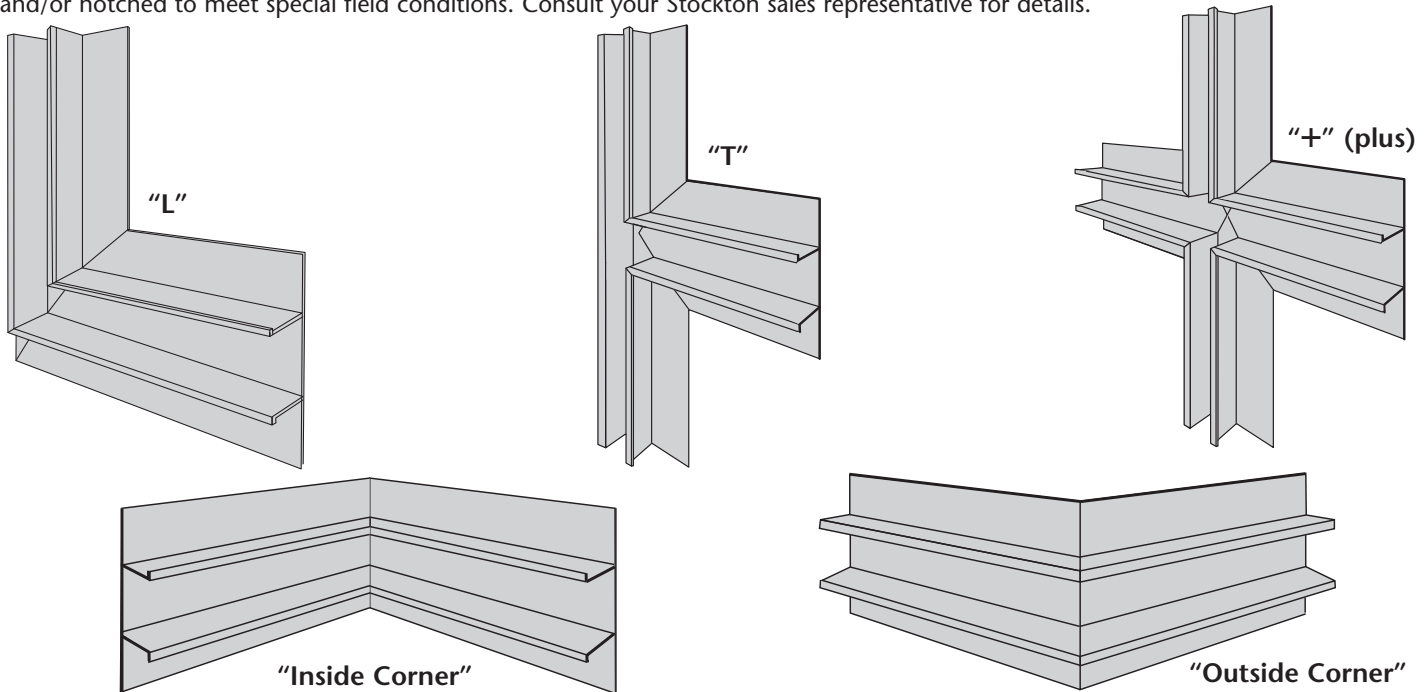

Finishes

Clear Anodized

The standard finish for Stockton Plaster Moldings is Clear Anodized, Architectural 200R1. This is an electrochemical conversion process that deposits an oxide film on the aluminum extrusion. The coating is extremely durable and resistant to most forms of corrosion and the satin finish gives the molding an aesthetically pleasing appearance.

Specifications

Standard Finish: Architectural 200R1, medium etch (AA-M32C10A21)

Optional Finish: Class II 204R1, medium etch (AA-M32C10A31)

Fluorophore Paint (Kynar/Hylar)[®]

Kynar/Hylar is a 70% fluoropolymer resin based 2-coat baked on paint that is offered as an optional finish where high durability is required and/or the moldings must match existing colors.

This premium finish is recommended for exterior applications where harsh conditions exist. It is extremely resistant to ultraviolet color degradation and chalking. It is available in a wide variety of colors.

Note: Certain colors require a Kynar XL (with topcoat) given the exotic nature of the color. Please advise the factory of the required color prior to job costing due to the fact that these colors require additional cost and minimum order quantities.

Specifications

Typical Finish meets or exceeds AAMA 605.2 Specification "Voluntary Specification for High Performance Organic on Architectural Extrusion Panels." Meets or exceeds a nominal dry film thickness of 1.2 mil. Kynar[®] is a Registered Trademark of Atochem North America, Inc.

Color Anodized

The following color anodized finishes are available as special order items: Gold, Light Bronze, Medium Bronze, Dark Bronze and Black. Color anodized finishes can vary from piece to piece. This is a characteristic of the anodizing process and should be taken into account prior to placing an order. Typically, the color of the extrusions will fall within a certain range, and this range can be established before anodizing. Check with factory for details.

Specifications

Color Anodized Finish: Integral colors to conform with designation 3AA-M112C22A32 of the Aluminum Association.

Alodine/Chem-Film

Alodine/Chem-film is a chemical conversion process that protects the aluminum extrusion until a primer coat can be applied in the field. Chemical conversion should be specified for all extrusions to be field painted.

Specifications

Chemical Conversion Finish: Conforms with ASTM D 1730 Type B and MIL-C-5541A.