

EXTRUDED

Ventilation

Many shapes are available vented to allow for air flow. All vent slots are 1/8" wide by 1" long, spaced 1 1/2" on center lengthwise. Multiple rows of vents are spaced laterally, 1/2" on center. Each lengthwise row of vent slots provides approximately one square inch of venting per lineal foot.

Note: The "V" designation in model numbers indicates vented ability.

Reveal width	Vent slots	Vent area per lineal foot (approx.)	Percent of area vented (approx.)
1/2"	1	1" square	15.0%
3/4"	1	1" square	12.5%
1"	1	1" square	9.4%
1 1/2"	2	2" square	12.5%
2"	3	3" square	14.1%
3"	5	5" square	14.3%
4"	5	5" square	14.5%
6"	10	10" square	20.8%

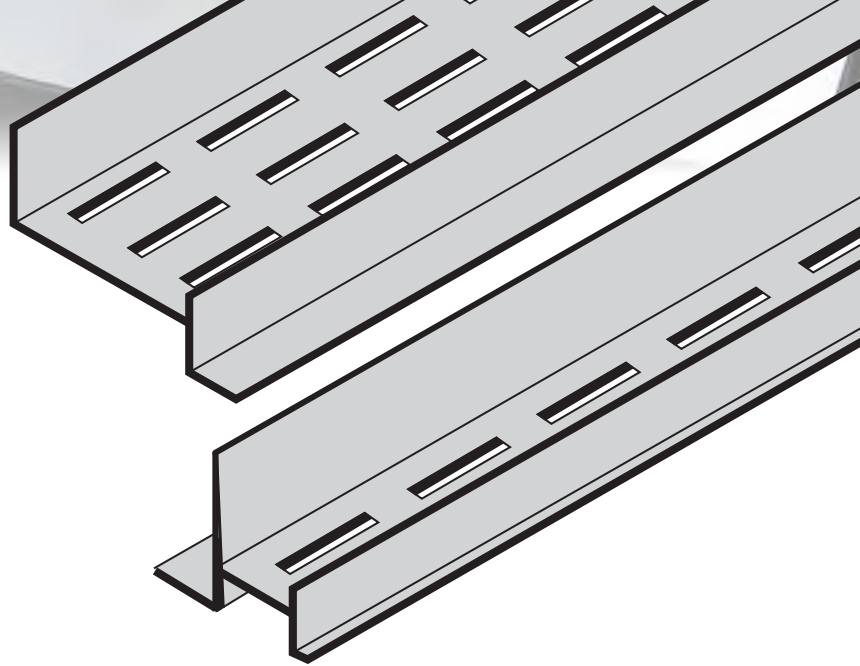

Note: not all extruded aluminum items are available vented in all size combinations. Please call 1-87-Stockton to verify availability.

Intersections

Custom fabricated mitered corners and intersections are available. Intersections are available in standard styles, which are shown on this page. Custom shapes and designs are also available. The intersections are heli-arc welded. Six inch legs are standard. Longer legs—up to two feet in length—are available. Different size reveal widths and shapes can be intersected. Moldings can be miter cut and/or notched to meet special field conditions. Please call customer service for details.

