



CUSTOM SIZES AVAILABLE!

Stockton Custom Fabrication
877-786-2587
custom@StocktonProducts.com



TFB: TruFlush™ Backing

- Faster Installation
- Eliminates Costly Backcharges
- Increase Production Installation, Plus Drywall, Taping And Finishing
- Increased Safety, No Grinders Needed, Only Chop Saw And Screw Gun
- Galvanized Steel (GS)
- Fixed Length, Single Piece Design
- Patent Pending

Low profile, return lip backing that provides increased load capacity. TruFlush™ Backing will eliminate build up, drywall cracking and drywall fastener popping. Available in 20 gauge or 16 gauge for 12", 16" and 24" stud spacing.

Note: Custom spacing and steel thickness available with extended lead times.

Most Common Sizes

W Sizes: 12", 16" and 24"

See Installation Guide For Load Testing Data



TRUFLUSH™

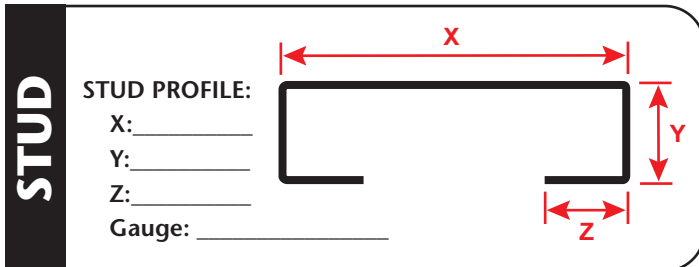

NEW

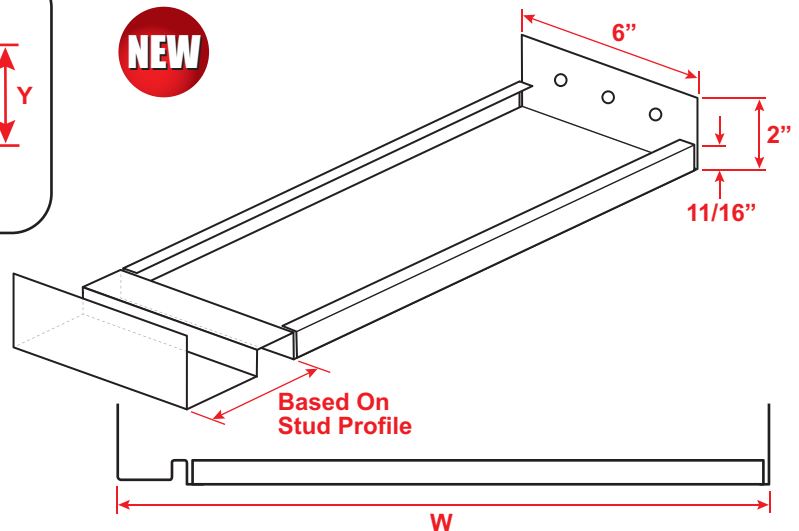

Materials And Finishes:

Details: stpro.us/MET

Galvanized Steel (GS) in 20 ga. or 16 ga. G60 standard (G90 optional)

ASTM Codes:

Details: stpro.us/ASTM

A1003, A653, A924, C645, C754, C955

QUOTE	Company: _____	QTY: _____	PO Number: _____
	Name: _____	Material/Gauge: _____	Job/Project: _____
	Address: _____	W Size: _____	Notes: _____
	City: _____		_____
	State/ZIP: _____		_____
	Phone: _____		_____
	eMail: _____		_____

877-786-2587 • StocktonProducts.com

