



**CUSTOM SIZES AVAILABLE!**

Stockton Custom Fabrication

877-786-2587

custom@StocktonProducts.com



**PRODUCTS®**

# J-B88: Long Flange J Bead

- Perfect Finished Product
- No More Cracking, Delamination, Warranty Issues or Excessive Buildup
- Saves Labor and Material
- Custom Sizes Available, Contact Customer Service For Details
- Patent Pending
- Includes 1/2" Weep Holes
- Available in Galvanized Steel (GS) or Aluminum (A)

Similar to the new SFC88 Short Flange "Finish Rite®" plaster trim, the J-B88 Long Flange J bead provides all the same features of controlling the brown coat thickness, but has a 3 1/2" nail flange and 1/2" diameter weep holes for those conditions where a weep function is required.

### Most Common Sizes

**W Sizes:** 1/8" or 3/16"

**X Sizes:** 7/8", 15/16" or 1"

**Y Sizes:** 3 1/2"

**Z Sizes:** 3/4"

**Length:** 120"

### Materials And Finishes:

Details: [stpro.us/MET](http://stpro.us/MET)

Galvanized Steel (GS), Galvalume® (GVM) or Aluminum (A)

### ASTM Codes:

Details: [stpro.us/ASTM](http://stpro.us/ASTM)

All Accessories are fabricated from prime galvanized steel G90 zinc coating by the hot dipped method, conforming to steel and coating specification ASTM A-653/A-653M or zinc alloy meeting ASTM B-69. Stainless Steel A480/A480M A580M (Stainless Steel) For installation and placement instructions refer to ASTM C1063, C841 and C926.

### Most Common Part Numbers:

<b>J88 018K078W312 034L</b>	J88: W=1/8, Y=3 1/2, Z= 3/4, GS, 10'
<b>J88 018K1516W312 034L</b>	J88: W=1/8, Y=3 1/2, Z= 3/4, GS, 10'
<b>J88 018K1W312 034L</b>	J88: W=1/8, Y=3 1/2, Z= 3/4, GS, 10'
<b>J88 316K078W312 034L</b>	J88: W=3/16, Y=3 1/2, Z= 3/4, GS, 10'

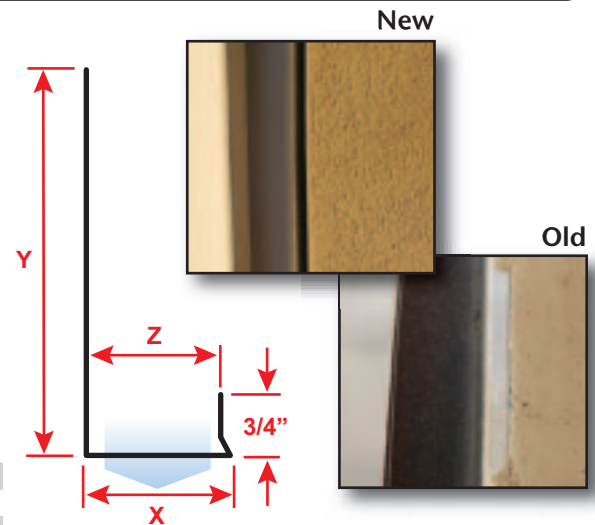
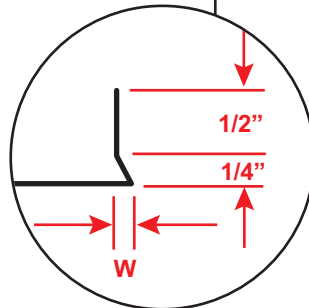
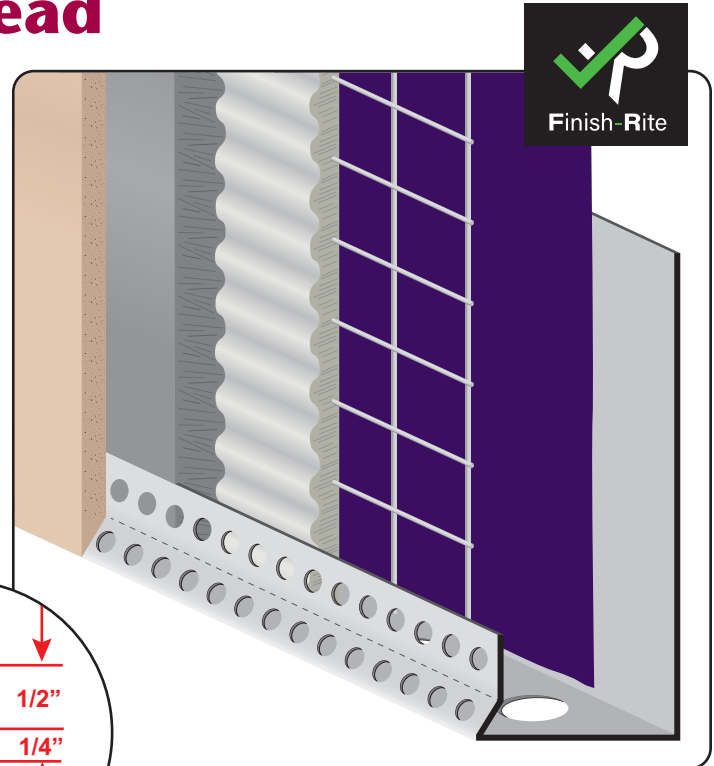

<b>QUOTE</b>	Company: _____	QTY: _____	PO Number: _____
	Name: _____	Material/Gauge: _____	Job/Project: _____
	Address: _____	W Size: _____	Notes: _____
	City: _____	X Size: _____	_____
	State/ZIP: _____	Y Size: _____	_____
	Phone: _____	Z Size: _____	_____
	eMail: _____	Length: _____	_____

**877-786-2587 • StocktonProducts.com**

